



*An Online CPD Course  
brought to you by  
CEDengineering.ca*

# Protecting Homes from High Wind Damage

Course No: S02-017  
Credit: 2 PDH

---

Allen Hughes, P.E.

---



Continuing Education and Development, Inc.

P: (877) 322-5800  
[info@cedengineering.ca](mailto:info@cedengineering.ca)

[www.cedengineering.ca](http://www.cedengineering.ca)

*This course was adapted from a compilation of several Federal Emergency Management Agency (FEMA) articles, which are in the public domain.*

# Against THE WIND

*Protecting Your  
Home From Hurricane  
Wind Damage*



American  
Red Cross



**D**uring a hurricane, homes may be damaged or destroyed by high winds and high waves. Debris can break windows and doors, allowing high winds inside the home. In extreme storms, such as Hurricane Andrew, the force of the wind alone can cause weak places in your home to fail.

After Hurricane Andrew, a team of experts examined homes that had failed and ones that had survived. They found four areas that should be checked for weakness—the roof, windows, doors, and if you have one, garage door. In this brochure, we discuss some things you can do to help make your home stronger *before* the next hurricane strikes. You may need to make some improvements or install temporary wind protection. It is important that you do these projects *now*, before a hurricane threatens.

While these projects, if done correctly, can make your home safer during a hurricane, they are no guarantee that your home won't be damaged or even destroyed. If you are told by authorities to evacuate, do so immediately, even if you have taken these precautions.

---

## The Roof

During a windstorm, the force of the wind pushes against the outside of your home. That force is passed along from your roof to the exterior walls and finally to the foundation. Homes can be damaged or destroyed when the energy from the wind is not properly transferred to the ground.

The first thing you should do is determine what type of roof you have. Homes with gabled roofs are more likely to suffer damage during a hurricane. A gabled roof looks like an A on the ends, with the outside wall going to the top of the roof (see Figure 1). The end wall of a home with a gabled roof takes a beating during a hurricane, and those that are not properly braced can collapse, causing major damage to the roof.

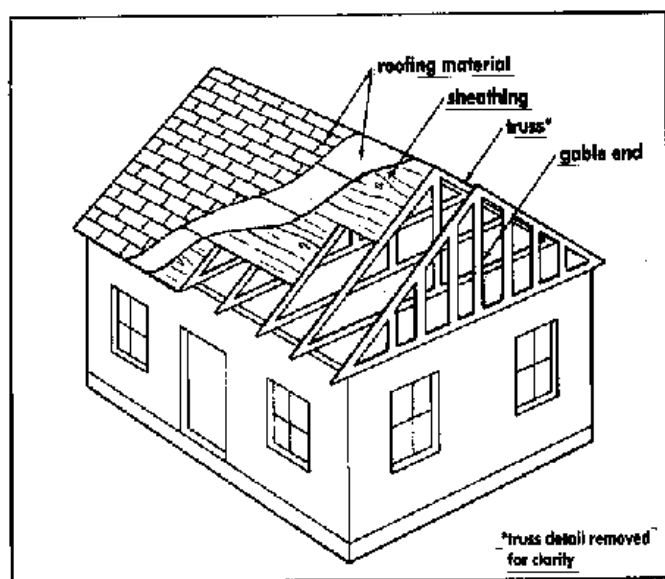

**Figure 1. Gabled Roof**

In most homes, gabled roofs are built using manufactured trusses. Sheets of roof sheathing, often plywood, are fastened to the trusses with nails or staples, and roofing material is fastened to the sheathing. In many cases, the only thing holding the trusses in place is the plywood on top. This may not be enough to hold the roof in place during a hurricane. Installing additional truss bracing makes your roof's truss system much stronger.

To inspect your roof's bracing, go into the attic. While working in your attic, you should wear clothing that covers your skin, work gloves, a hat, eye protection, and a dust mask. If your attic does not have a floor, be careful to walk only on the wood joists, or install boards wide enough to walk on as you work. Notice how the plywood is attached to the truss system. If most of the large nails or staples coming through the sheathing have missed the trusses, consider having the sheathing properly installed.

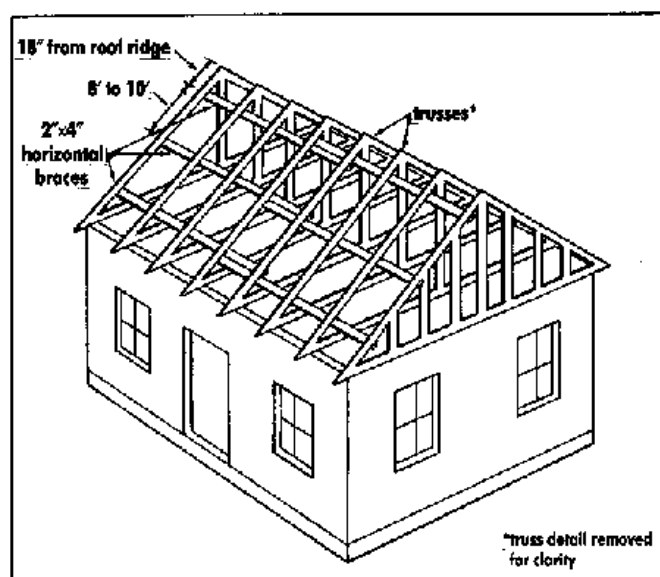

**Figure 2. Truss Bracing**

### Truss bracing

In gabled roofs, truss bracing usually consists of 2×4s that run the length of the roof. If you do not have truss bracing, it should be installed. You can do this yourself or hire a professional. Install 2×4s the length of your roof, overlapping the ends of the 2×4s across two trusses (see Figure 2). Braces should be installed 18 inches from the ridge, in the center span, and at the base, with 8 to 10 feet between the braces. Use two 3-inch, 14-gauge wood screws or two 16d (16 penny) galvanized common nails at each truss. Because space in attics is generally limited, screws may be easier to install.

### Gable end bracing

Gable end bracing consists of 2×4s placed in an “X” pattern from the top center of the gable to the bottom center brace of the fourth truss, and from the bottom center of the gable to the top center brace of the fourth truss (see Figure 3). Use two 3-inch, 14-gauge wood screws or two 16d galvanized common nails to attach the 2×4s to the gable and to each of the four trusses.

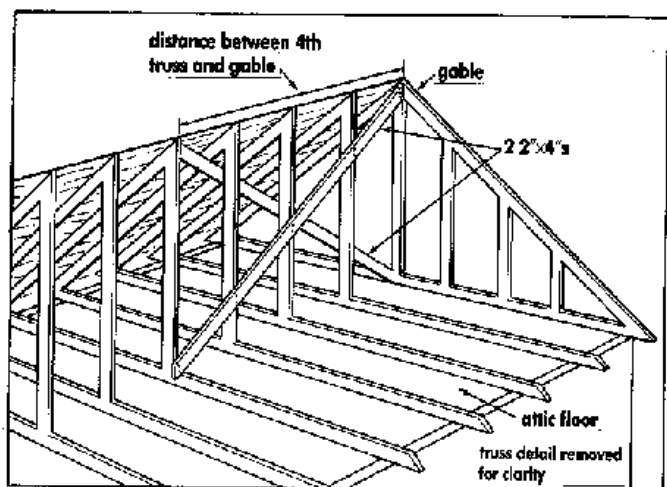

Figure 3. Gable End Bracing

### Hurricane straps

There are many types of roof design. Regardless of your type of roof, hurricane straps are designed to help hold your roof to the walls. While you are in the attic, inspect for hurricane straps of galvanized metal (see Figure 4). Hurricane straps may be difficult for homeowners to install. You may need to call a professional to retrofit your home with hurricane straps. Check with your local government building officials to see if hurricane straps are required in your area.

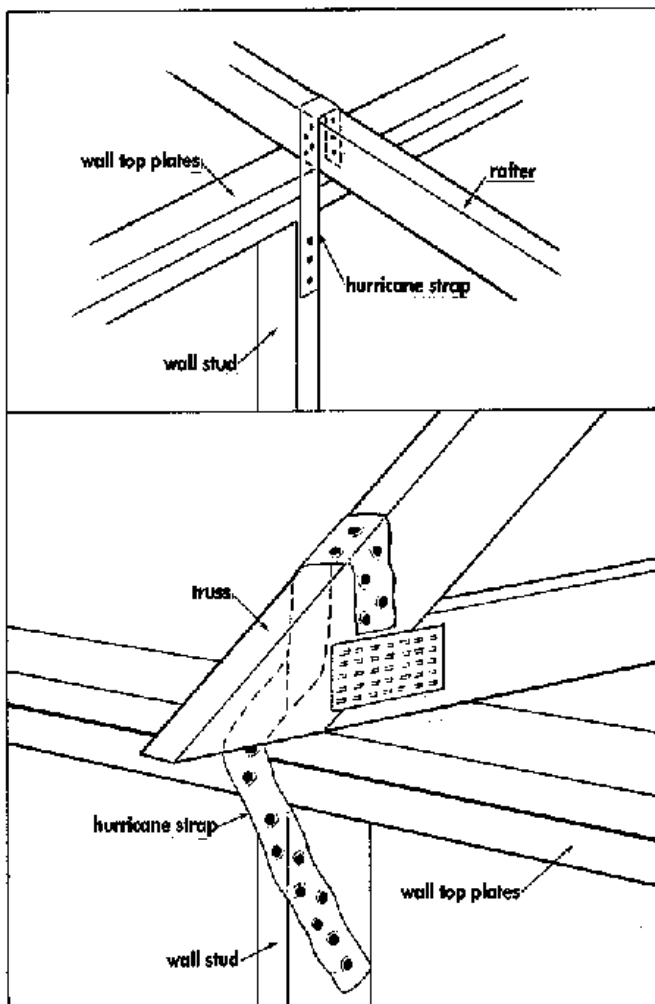

Figure 4. Hurricane Straps

## Exterior Doors and Windows

The exterior walls, doors, and windows are the protective shell of your home. If your home's protective shell is broken, high winds can enter and put pressure on your roof and walls, causing damage. You can protect your home by strengthening the doors and windows.

### Double entry doors

Most double doors have an active and an inactive or fixed door (see Figure 5). Check to see how the fixed door is secured at the top and bottom. The bolts or pins that secure most doors are not strong enough.

Some door manufacturers provide reinforcing bolt kits made specifically for their doors. Check with your local building supplies retailer to find out what type of bolt system will work for your door. The door bolt materials should cost from \$10 to \$40, depending on the type and finish. Doors with windows will need additional protection from flying debris. See the section on storm shutters for how to protect windows.

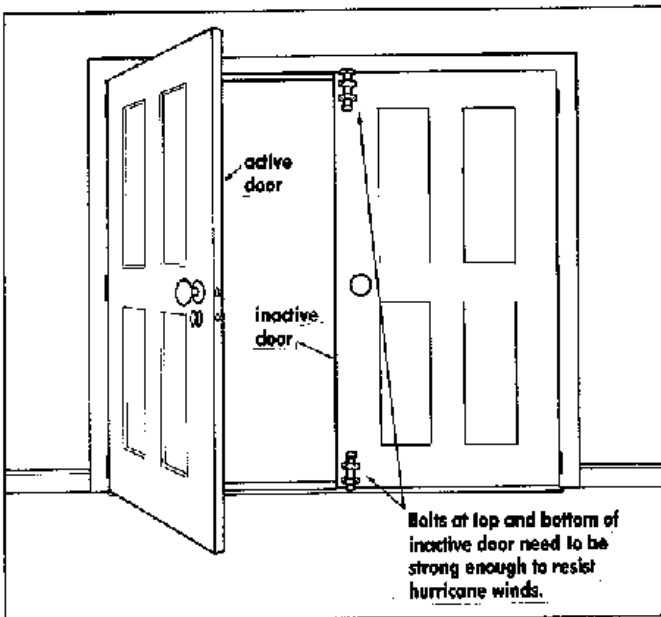

Figure 5. Double Entry Doors

### Double-wide garage doors

Double-wide (two-car) garage doors can pose a problem during hurricanes because they are so large that they wobble as the high winds blow and can pull out of their tracks or collapse from wind pressure. If garage doors fail, high winds can enter your home through the garage and blow out doors, windows, walls, and even the roof.

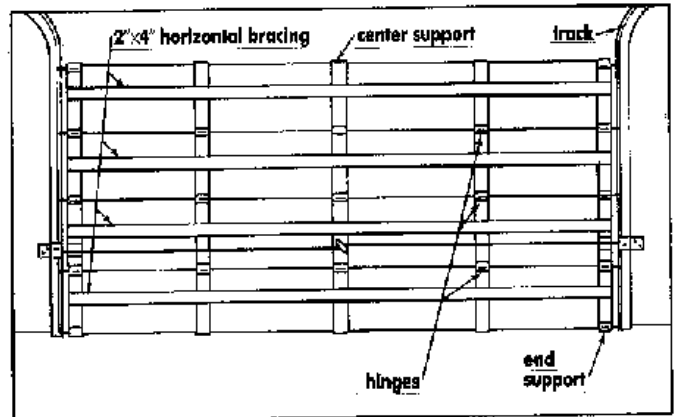

Figure 6. Double-Wide Garage Doors

Certain parts of the country have building codes requiring garage doors to withstand high winds. You should check with your local government building officials to see if there are code requirements for garage doors in your area. Some garage doors can be strengthened with retrofit kits. Check with your local building supplies retailer to see if a retrofit kit is available for your garage door. You can expect to pay from \$70 to \$150 to retrofit your garage door.

Many garage doors can be reinforced at their weakest points. Retrofitting your garage doors involves installing horizontal bracing onto each panel. This horizontal bracing can be part of a kit from the garage door manufacturer. You may also need heavier hinges and stronger center supports and end supports for your door (see Figure 6).



Check the track on your garage door. With both hands, grab a section of each track and see if it is loose or if it can be twisted. If so, a stronger track should be installed. Make sure that it is anchored to the 2×4s inside the wall with heavy wood bolts or properly attached to masonry with expansion bolts (see Figure 7).

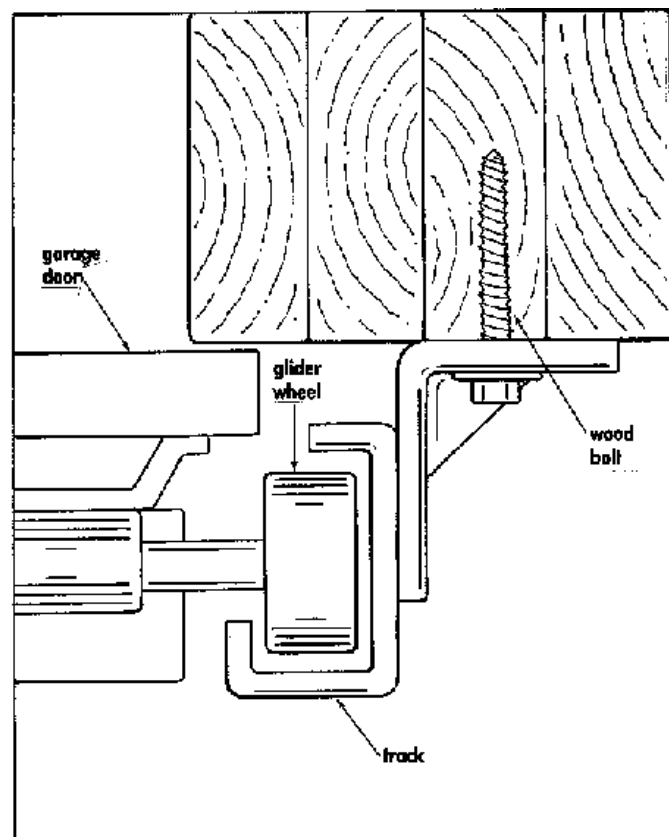

**Figure 7. Garage Door Track Anchoring**

After you have retrofitted your door, it may not be balanced. To check, lower the door about halfway and let go. If it goes up or down, the springs will need adjusting. The springs are dangerous and should be adjusted by a professional.

If you are unable to retrofit your door, you can purchase specially reinforced garage doors designed to withstand winds of up to 120 miles per hour. These doors can cost from \$400 to \$450 (excluding labor) and should be installed by a professional.

## Storm shutters

Installing storm shutters over all exposed windows and other glass surfaces is one of the easiest and most effective ways to protect your home. You should cover all windows, French doors, sliding glass doors, and skylights. There are many types of manufactured storm shutters available. For more information on manufactured shutters, check with your local building supplies retailer. If you install manufactured shutters, follow the manufacturer's instructions carefully.

Before installing shutters, check with your local building official to find out if a building permit is required. It is important that you have your shutters ready now, and that you mark and store them so they can be easily installed during a hurricane watch.

Plywood shutters that you make yourself, if installed properly, can offer a high level of protection from flying debris during a hurricane. Plywood shutters can be installed on all types of homes.

Measure each window and each door that has glass, and add 8 inches to both the height and width to provide a 4-inch overlap on each side of the window or door. Sheets of plywood are generally 4×8 feet. Tell your local building supply retailer the size and number of openings you need to cover to determine how many sheets to buy.

To install plywood shutters you will need bolts, wood or masonry anchors, large washers, and 5/8-inch exterior-grade plywood. For windows 3 feet by 4 feet or smaller installed on a wood frame house, use 1/4-inch lag bolts and plastic-coated permanent anchors. The lag bolts should penetrate the wall and frame surrounding the window at least 1 3/4 inches. For larger windows, use 3/8-inch lag bolts that penetrate the wall and frame surrounding the window at least 2 1/2 inches. For windows 3 feet by 4 feet or smaller installed on a masonry house, use 1/4-inch expansion bolts and galvanized permanent expansion anchors. The expansion bolt should penetrate the wall at least 1 1/2 inches. For larger windows, use 3/8-inch expansion bolts that penetrate the wall at least 1 1/2 inches. The tools you will need are a circular or hand saw, a drill with the appropriately sized bits, a hammer, and a wrench to fit the bolts. To be safe, use eye protection and work gloves.



Cut the plywood to the measurements for each opening. Drill holes 2 1/2 inches from the outside edge of the plywood at each corner and at 12-inch intervals. Drill four holes in the center area of the plywood to relieve pressure during a hurricane.

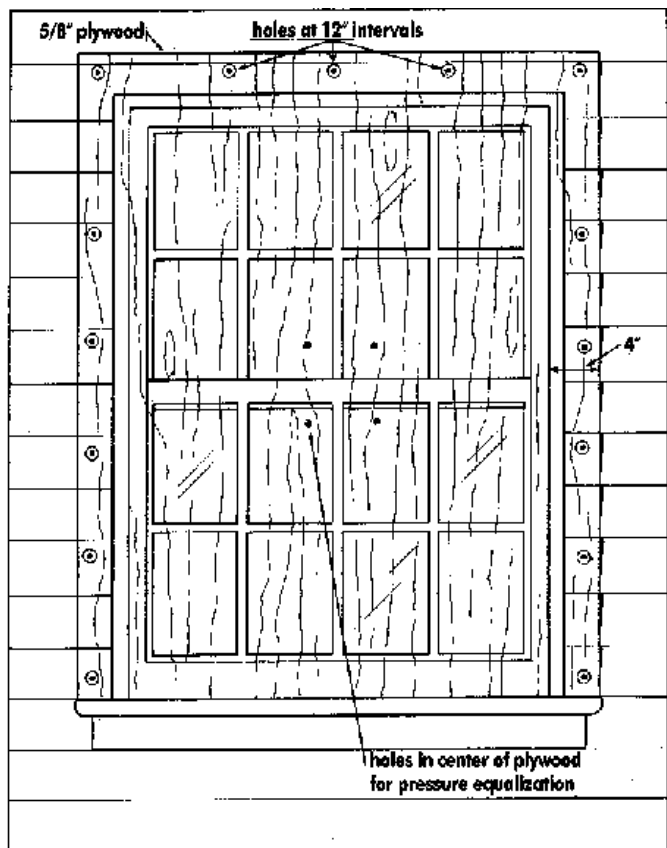

**Figure 8. Plywood Storm Shutters**

Place the plywood over the opening and mark each hole position on the outside wall (see Figure 8). Drill holes with the appropriate size and type of bit for the anchors. Install the anchors, the plywood, and the bolts to make sure they fit properly. On wood-frame houses, make sure that the anchors are secured into the solid wood that frames the door or window and not into the siding or trim. Mark each shutter so you will know where it is to be installed and store them and the bolts in an accessible place.

If the opening is larger than one sheet of plywood, you will need to make shutters with 2x4 bracing. This bracing can be two 2x4s at the middle and bottom of the two sheets of plywood, evenly spaced, with the 2-inch side attached to the inside of the storm shutter (see Figure 9). Attach the 2x4s to the outside of the storm shutter with 2-inch, 10-gauge wood screws before installing the shutter.

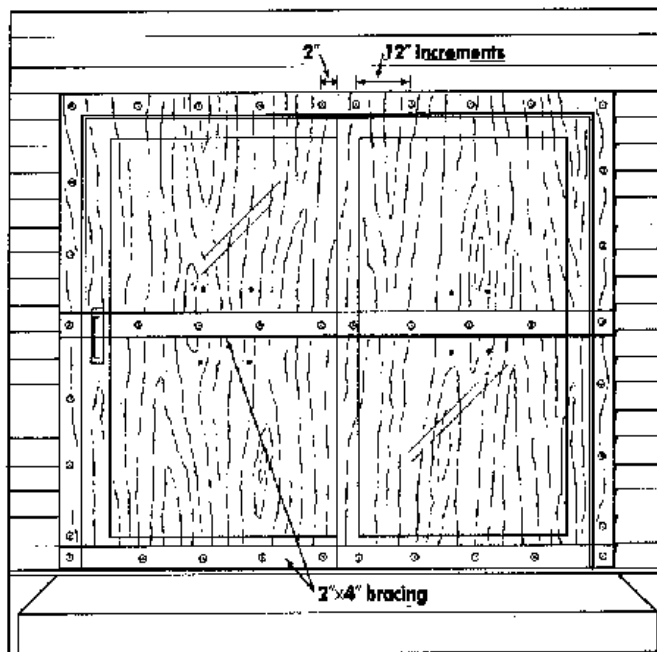

**Figure 9. Large Plywood Storm Shutters**

The recommendations in this brochure are not intended to replace local building code requirements or to serve as the only options for protecting your home from hurricane wind damage. For more information on protecting your home from hurricane wind damage, contact your local building official; your local building supply retailer; or a building professional, such as an engineer, architect, or experienced contractor.

# Secure Built-Up and Single-Ply Roofs



# FEMA

## PROTECTING YOUR PROPERTY FROM HIGH WINDS

Built-up and single-ply roofs are common on commercial buildings. Built-up roofs consist of multiple layers of felt and asphalt; single-ply roofs consist of one waterproof membrane. These roofs are often damaged when high winds tear away the metal edge flashing or coping around the perimeter of the roof. Once the flashing or coping is gone, the wind can peel back the roofing material and expose the interior of the building to the elements. The major building codes do not address the wind resistance of flashings and copings.

Whenever your built-up or single-ply roof is repaired or replaced, your roof designer or roofing contractor should ensure that the flashing and coping are made of a corrosion-resistant metal, such as aluminum, and are securely attached to the building with screws, concrete spikes, or a continuous cleat. Using a supplementary attachment method to provide additional strength is recommended. For single-ply roofs, a continuous bar placed over the membrane (see detail figures) is an effective means of strengthening the attachment.

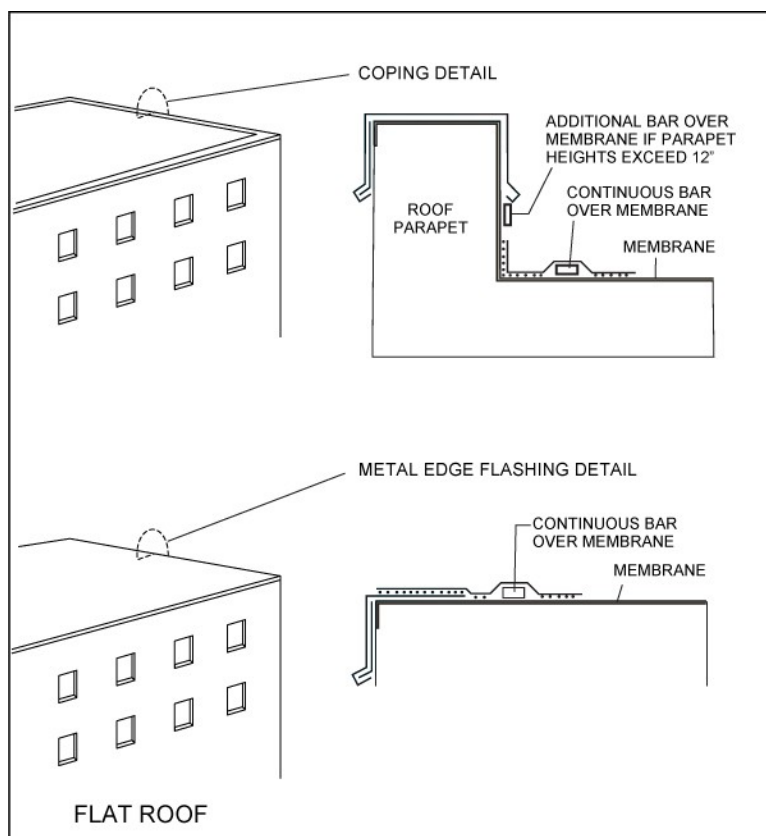

## BENEFITS OF UTILIZING THIS MITIGATION STRATEGY

- Helps to prevent damage to a structure and its contents
- Helps to prevent injuries

## TIPS

Keep these points in mind when you have your built-up or single-ply roof repaired or replaced:

- ✓ Single-ply membranes that are fully adhered are less susceptible to damage than mechanically attached or loose-laid air-pressure-equalized membranes.
- ✓ Some local building codes may require that roofs meet design standards for resisting uplift forces (an example is the latest version of the American Society of Civil Engineers Standard ASCE 7). Ask your local building official whether any special requirements apply in your area.
- ✓ Your local building official may be able to inspect your roof and recommend changes that will help protect it from high winds.

- ✓ If you add stone ballast or pavers to your roof, make sure the roof parapet is high enough and that the pavers or individual stones are large enough to resist being picked up and carried by the wind (refer to *Wind Design Standard for Ballasted Single-Ply Roofing Systems*).
- ✓ Roof warranties typically will not cover damage caused by strong storms.
- ✓ If you are considering a reroofing project, properly securing rooftop equipment should be investigated prior to reroofing.

## **ESTIMATED COST**

A roofing contractor will charge approximately \$1 to \$2 per linear foot to replace aluminum fascia cap when the roof is being replaced. The cost would be much higher if the fascia is replaced separately.

# Secure Composition Shingle Roofs



# FEMA

## PROTECTING YOUR PROPERTY FROM HIGH WINDS

When composition shingles are not securely attached, they can be damaged or torn away by high winds. When this happens, the interior of the structure becomes vulnerable to rainwater infiltration. If your composition shingle roof is being repaired or replaced, your roof designer or roofing contractor should make sure that the following requirements have been met (see figure):

- Each shingle should be held by at least six nails or staples, which should be installed below the edge of the upper, overlapping row of shingles.
- A waterproof underlayment should be installed beneath the shingles. When well attached, it temporarily protects the building from rain if shingles are torn away by the wind.

The roof sheathing (typically plywood panels) should be at least 15/32-inch thick and should be securely attached to the roof trusses. (Nails in older wood roof sheathing are often farther apart than recommended, especially in areas subject to high winds. Your roof designer or roofing contractor should check with local building officials for nailing requirements.)

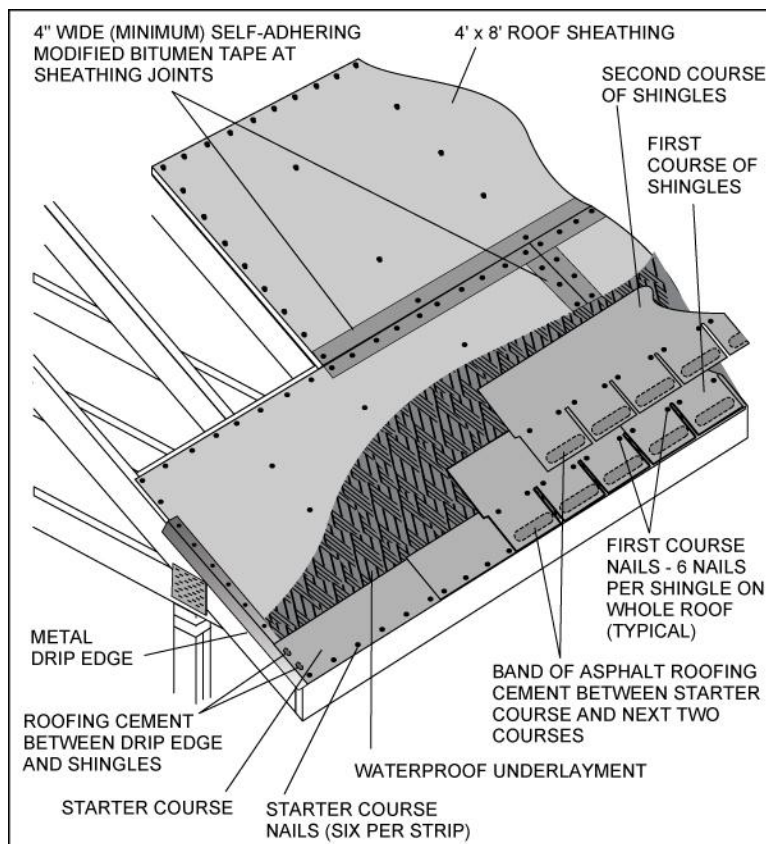

## BENEFITS OF UTILIZING THIS MITIGATION STRATEGY

- ✓ Helps to prevent damage to a structure and its contents
- ✓ Helps to prevent injuries

## TIPS

Keep these points in mind when you have your composition shingle roof repaired or replaced:

- ✓ If you are having an old roof replaced, your contractor should remove the existing shingles and underlayment rather than install new shingles over them. This approach allows the contractor to inspect the sheathing and make any repairs that may be necessary.
- ✓ All nails used to attach the roof sheathing must penetrate the underlying roof trusses, otherwise the sheathing will not be securely attached and can be more easily torn away by high winds. Inadequate attachment of roof sheathing, resulting from poor workmanship, has been a common cause of roof failures during hurricanes and other storms with high winds.

- ✓ If your building is in a hurricane-prone area, the following precautions are recommended:
  - The general recommendations given in the Fifth Edition of the National Roofing Contractors Association (NRCA) *Steep-Slope Roofing Manual* should be followed.
  - Shingles should be attached with nails, not staples.
  - The first course of shingles should be sealed to the starter strip with dabs or bands of roof cement. Details are provided in FEMA 499, Technical Fact Sheet No. 7.3.
  - If your building is within 3,000 feet of saltwater, the nails should be hot-dip galvanized or stainless steel.
  - Your roofing designer should try to obtain information from manufacturers about bond strength and nail pull-through resistance, and then use products with values in the upper ranges of available strengths.
- ✓ Check local code requirements for roof repair or replacement criteria. Your local building official should be able to provide additional recommendations.
- ✓ Provide your roofing contractor with FEMA P-499, *Home Builder's Guide to Coastal Construction*, "Asphalt Shingle Roof for High-Wind Regions," Technical Fact Sheet No. 7.3.

### **ESTIMATED COST**

A roofing contractor will charge approximately \$10 to \$15 per square foot of roof area to remove and replace shingles and underlayment.



# Brace Gable End Roof Framing

**FEMA**

## PROTECTING YOUR PROPERTY FROM HIGH WINDS

Gable end roofs are more susceptible to damage from high winds than hip or flat roofs. The gable end presents a large, flat obstacle to the wind and receives its full force. If the framing of the gable end and the entire roof is not adequately braced to resist the wind, the roof can fail. Roof failures, especially in unbraced gable roofs, are a common cause of major damage to structures and their contents in high winds.

If your property has a gable roof, check to see whether the roof framing is braced. The top figure shows a cutaway view of an unbraced gable end roof. This is a truss roof, but some gable end roofs are constructed with rafters rather than trusses. Both types should be braced as shown in the bottom figure. If you are unsure whether your gable end roof is adequately braced, check with your local building department. After inspecting your roof framing, a building official can tell you whether bracing is required and if so, how it should be added.

### BENEFITS OF UTILIZING THIS MITIGATION STRATEGY

- Helps to prevent roof failure, which can lead to major damage of a structure and its contents
- Helps to prevent injuries to occupants

### TIPS

Keep these points in mind if you have bracing added to a gable end roof:

- ✓ Bracing can be added fairly easily, but you should have a contractor perform the work to make sure that the bracing is properly designed and attached.
- ✓ If you have a building official inspect your roof framing, ask about other changes you may be able to make to your property to protect it from high winds.

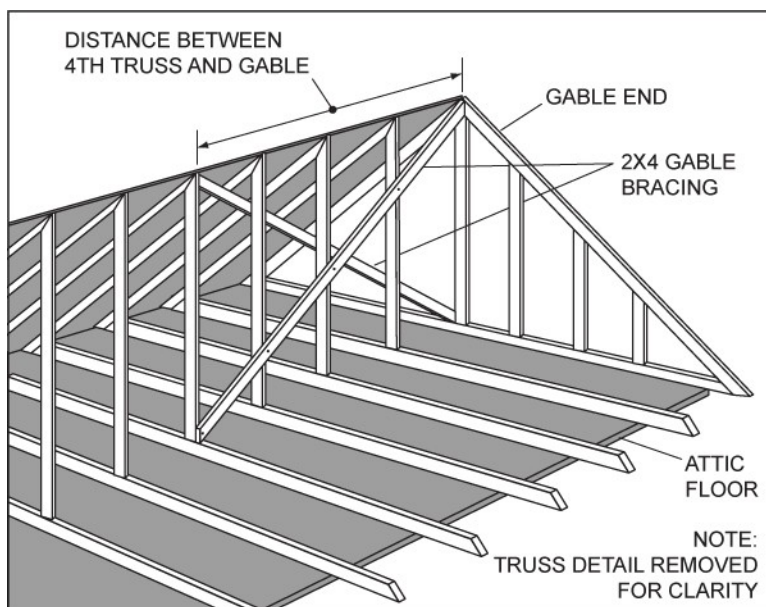
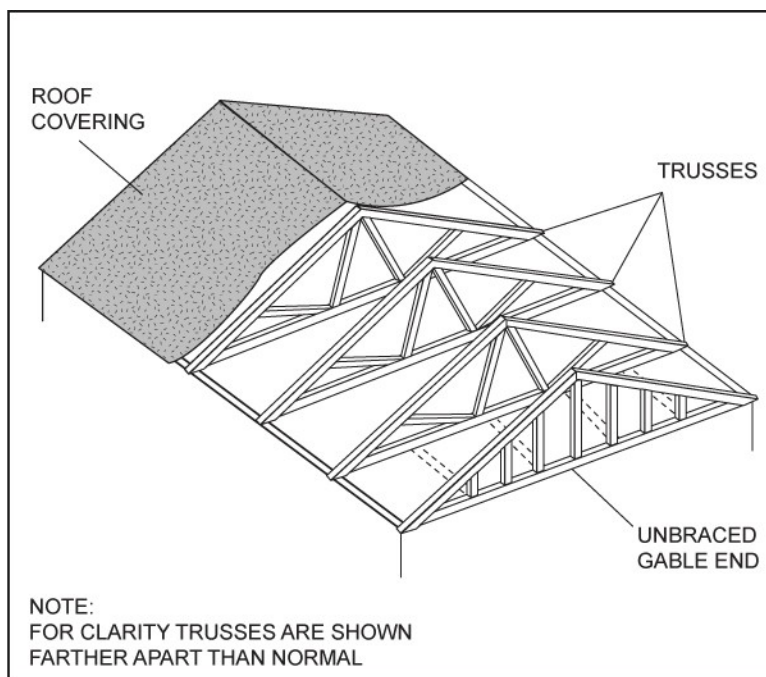

- ✓ The detail featured on this Fact Sheet provides increased resistance of the gable end to wind loads. For another gable end retrofit that meets current building code requirements, see FEMA P-804, *Wind Retrofit Guide for Residential Buildings*.

## **ESTIMATED COST**

If you hire a contractor to brace a gable end roof, you can expect to pay about \$100 for each gable end. This figure is for a gable end about 30 feet long. Bracing longer gable ends may be slightly more expensive.

# Protect Windows and Doors with Covers



FEMA

## PROTECTING YOUR PROPERTY FROM HIGH WINDS

High winds and windborne debris can easily break unprotected windows and cause doors to fail. Once wind enters a structure, the likelihood of severe structural damage increases, and the contents of the building will be exposed to the elements. The most reliable method of protecting windows and doors is installing permanent storm shutters. Alternatives include using temporary plywood covers, mesh or screen systems, and replacing existing windows and doors with impact-resistant windows and doors.

Permanent storm shutters are usually made of aluminum or steel and are attached to a building in such a way that they can be closed quickly before a storm arrives. One type is the “rolldown” shutter (see figure on this page), which is contained in a housing mounted above the window and lowered when necessary. Manually operated and motor-driven models are available.

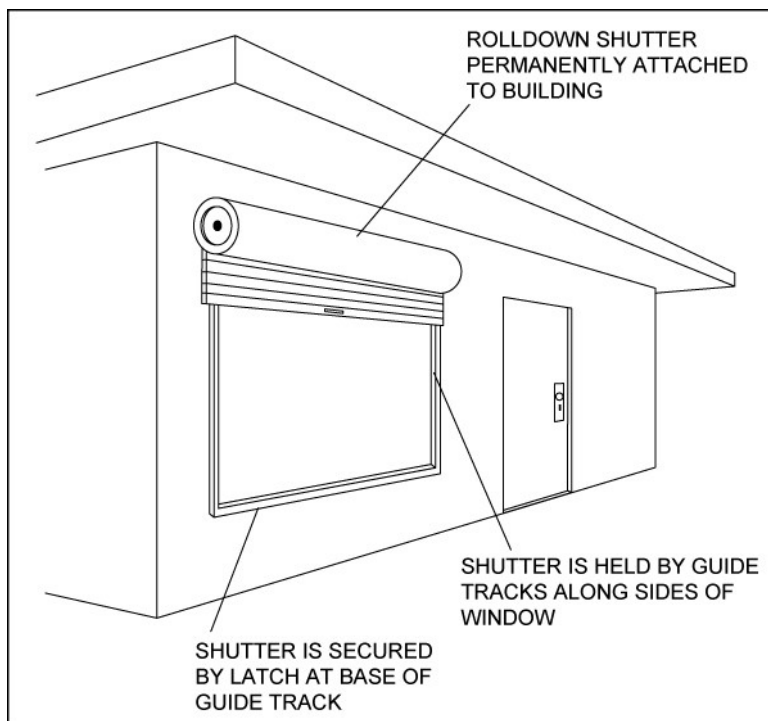

While permanent storm shutters can usually be closed quickly and easily, temporary covers can be an economical alternative and can be installed fairly quickly if the necessary preparations are made. Plywood covers can also be used to protect sliding glass doors and French doors (see figure on page 2).

## BENEFITS OF UTILIZING THIS MITIGATION STRATEGY

- Helps to prevent damage to a structure and its contents

## TIPS

Keep these points in mind when you install shutters or use temporary plywood, fiberglass, metal panel, or mesh covers to protect your windows and doors:

- ✓ Always consider using permanent storm shutters if you live in an area where you know you will need to act quickly to protect your windows. If your property is in an area where you will have little warning of high winds, permanent shutters that can be closed quickly, such as the rolldown shutter, are better than temporary plywood covers, which must be retrieved from storage and mounted with bolts or screws.
- ✓ If you decide to buy permanent shutters, look for models that meet the wind load and impact standards established for your area. These standards can be obtained from your local building official. If you have any questions about the strength of a specific model, check with the manufacturer. Permanent shutters are available in a wide range of sizes, so you can use them to protect many types of windows and doors, as well as large areas of glass.

✓ If you decide to use temporary plywood covers, you may want to hire a contractor or handyman to make them for you. If you do the work yourself, you will need to cut the plywood and drill holes for screws or lag bolts in each cover and in the wall around each window. You should follow a prescriptive design appropriate for the windspeed of the area. **DO NOT** use oriented strand board (OSB). The screws or lag bolts should be placed along the top, bottom, and sides of each cover, and they should be long enough to penetrate the wall studs around the window, and not just the siding or wall covering.

✓ Don't wait until a hurricane or high wind warning is issued to make temporary covers; you probably won't have time. Make them during the "off season" so that you'll be ready to install them at any time. Store the mounting screws or lag bolts with the covers, in a place where they are readily accessible – don't stack heavy boxes or other hard-to-move materials on top of or around the covers. Use a numbering or lettering system that shows which cover goes with which window.

✓ If you buy motor-driven shutters, make sure they also can be operated manually if the power fails.

✓ If you are constructing a new building in an area subject to high winds, avoid designs that include large areas of glass, windows with multiple panels, and double entry doors. The widths of individual doors and windows should not exceed 3 feet.

✓ Check the local building code for windborne debris protection requirements in your area.

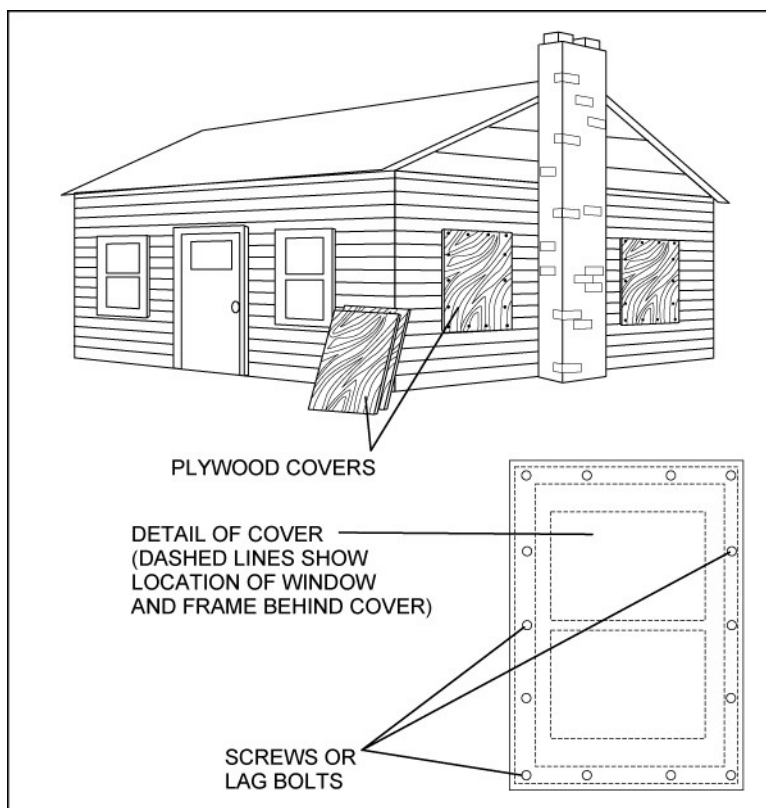

## ESTIMATED COST

Storm shutters can cost \$50 to \$60 per square foot of window. A set of shutters for a 3-foot by 4-foot window will cost approximately \$600 to \$720. The cost of a plywood cover will also depend on the size of the window. If you do the work yourself, you can expect plywood to cost about \$0.60 per square foot. Screws or lag bolts, including washers, will cost about \$0.10 to \$0.15 each. For example, protecting a window that is 3 feet wide and 4 feet high will cost about \$10. This figure covers only the materials you will have to buy and excludes the cost of any tools you use and the value of your time. If you hire a contractor or handyman to do the work, you will have to pay for time as well as materials.

# Reinforce or Replace Garage Doors



FEMA

## PROTECTING YOUR PROPERTY FROM HIGH WINDS

High winds from hurricanes and tornadoes can damage garage doors or even blow them in. If wind enters a garage, it can cause dangerous and expensive structural damage. Reinforcing your garage door helps you protect not only your garage, but its contents as well.

The garage door industry strongly recommends that any determination concerning the need to reinforce or replace a garage door be based on an inspection by a trained door systems technician or a qualified professional engineer. Adding weight to a garage door in the form of reinforcement may require an adjustment to or replacement of the door's counterbalance system. Only a trained door systems technician should perform the adjustments or replacement. An inspection may find that other improvements should be made to an existing door, and if the door is old or damaged, replacement with a stronger door system may be recommended.

### BENEFITS OF UTILIZING THIS MITIGATION STRATEGY

- Helps to prevent structural damage
- Helps to prevent damage to or loss of contents in the garage

### TIPS

Keep these points in mind when an inspection by a trained door systems technician or qualified professional engineer has determined that your garage door needs to be reinforced or replaced:

- ✓ Because of the extreme amount of stored energy in the door counterbalance system combined with the potential impact on the counterbalance system's effectiveness when weight is added to an existing door, reinforcing a garage door is a job that should be done only by a trained door systems technician.
- ✓ A local garage door professional should be able to assess the wind load requirement of your garage door, which is based on size, local design wind speed, and location on the structure, among other factors. The Door & Access Systems Manufacturers Association International (DASMA) can also be of help in this area.

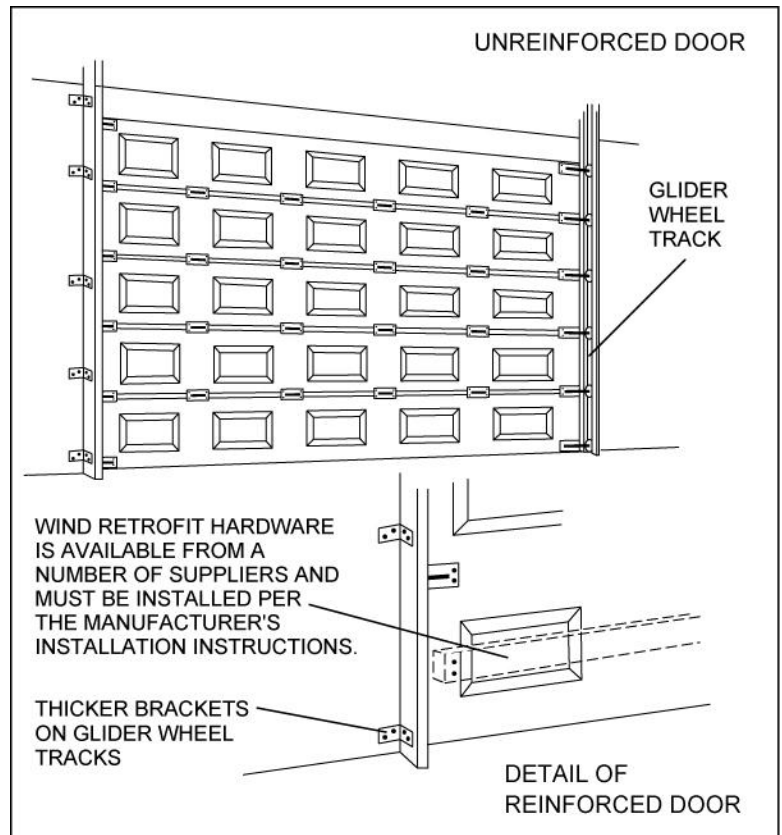

- ✓ Don't wait until a hurricane warning is issued to have your garage door evaluated; there will probably not be enough time for this service to be provided.
- ✓ Glazing (windows) in a garage door can be broken by windborne debris and should be avoided. If glazing is installed, it should be protected. Your local garage door professional or DASMA may be able to advise you on garage door glazing and the governing requirements.

## **ESTIMATED COST**

If you hire a contractor to reinforce or replace an existing two-car garage door, you can expect to pay about \$600. However, this cost can vary depending on the size and type of door.



FROM THE WEB PAGE

<http://www.eeri.org/mitigation/files/resources-for-success/00070.pdf>

## FEDERAL EMERGENCY MANAGEMENT AGENCY

### ARE YOU AT RISK?

If you aren't sure whether your house is at risk from hurricanes or tornadoes, check with your local building official, city engineer, or planning and zoning administrator. They can tell you whether you are in an area where these high-wind events occur. Also, they usually can tell you how to protect yourself and your house and property.

### WHAT YOU CAN DO

Hurricane and tornado protection can involve a variety of changes to your house and property – changes that can vary in complexity and cost. You may be able to make some types of changes yourself; however, complicated or large-scale changes and those that affect the structure of your house or its electrical wiring and plumbing should be carried out only by a professional contractor licensed to work in your state, county, or city. One example of hurricane and tornado protection is reinforcing garage doors to protect them from damage by high winds, or replacing them with doors that are more wind-resistant. These are things that should be done only by a trained door systems technician.

## REINFORCE OR REPLACE GARAGE DOORS

High winds from hurricanes and tornadoes can damage garage doors or even blow them in. If wind enters a garage, it can cause dangerous and expensive structural damage. Reinforcing your garage door helps you protect not only your garage, but its contents as well.

The garage door industry strongly recommends that any determination concerning the need to reinforce or replace a garage door be based on an inspection by a trained door systems technician or a qualified professional engineer. Adding weight to a garage door in the form of reinforcement may require an adjustment to or replacement of the door's counterbalance system. Only a trained door systems technician should perform the adjustments or replacement. An inspection may find that other improvements should be made to an existing door, and if the door is old or damaged, replacement with a stronger door system may be recommended.

### TIPS

Keep these points in mind when an inspection by a trained door systems technician or qualified professional engineer has determined that your garage door needs to be reinforced or replaced:

- Because of the extreme amount of stored energy in the door counterbalance system combined with the potential impact on the counterbalance system's effectiveness when weight is added to an existing door, reinforcing a garage door is a job that should be done only by a trained door systems technician.
- A local garage door professional should be able to assess the wind load requirement of your garage

door, which is based on size, local design wind speed, and location on the structure, among other factors. The Door & Access Systems Manufacturers Association International (DASMA) can also be of help in this area.

- Don't wait until a hurricane warning is issued to have your garage door evaluated; there will probably not be enough time for this service to be provided.
- Glazing (windows) in a garage door can be broken by windborne debris and should be avoided. If glazing is installed, it should be protected. Your local garage door professional or DASMA may be able to advise you on garage door glazing and the governing requirements.

## ESTIMATED COST

If you hire a contractor to reinforce or replace an existing two-car garage door, you can expect to pay about \$600. However, this cost can vary depending on the size and type of door.

# Secure Metal Siding and Metal Roofs



FEMA

## PROTECTING YOUR PROPERTY FROM HIGH WINDS

High winds can damage buildings with metal siding and metal roofs in primarily two ways:

- If the siding and roofing panels are not adequately attached to the frame of the building, the force exerted by the wind can lift them, possibly to the point where the fasteners pull through or break. When this occurs, entire panels can be torn off.
- Windborne debris can puncture siding or roofing panels and make them more susceptible to further wind damage.

In both situations, wind will be able to enter the building, increasing the likelihood of severe structural damage inside as well as injuries.

Metal siding and roofing in high-wind areas should be securely attached to the frame of the building with exposed fasteners such as screws or bolts or with concealed clips. The spacing of the fasteners or clips will depend on their strength and on the design and strength of the siding and roofing panels. In general, fasteners should be more closely spaced at the edges of panels (see figure). Also, all edges of siding, such as along the corners of the building, should be covered with a metal cap or molding and secured so that wind cannot work its way underneath. For information on additional types of siding (vinyl, wood, and fiber cement), refer to FEMA P-499, *Home Builder's Guide to Coastal Construction*, Technical Fact Sheet No. 5.3.

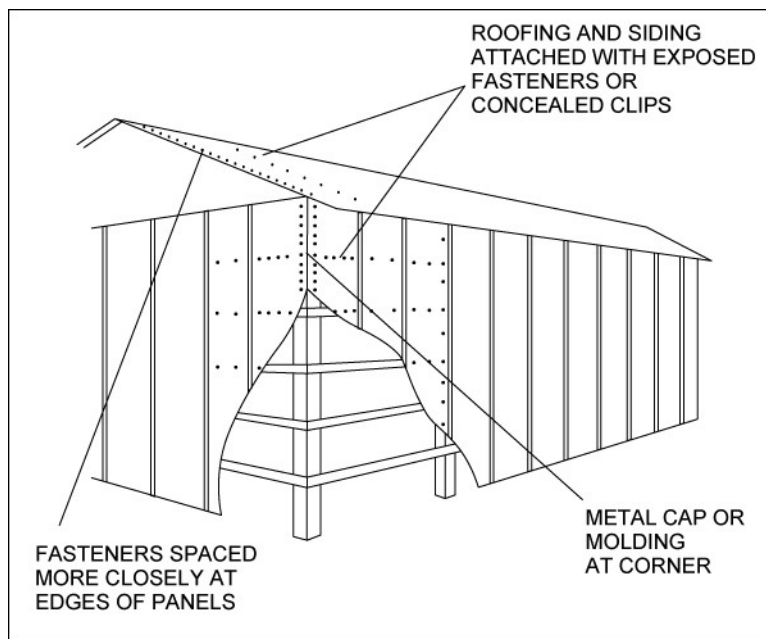

For buildings within 3,000 feet of the ocean, use corrosion resistant fasteners.

## BENEFITS OF UTILIZING THIS MITIGATION STRATEGY

- Helps to prevent damage to a structure and its contents
- Helps to prevent injuries from large windborne debris

## TIPS

Keep these points in mind when you inspect and repair metal siding and roofs:

- ✓ Have your buildings inspected periodically and repaired as necessary. Loose or missing connectors, rust, and damage caused by past storms can leave metal siding and roofing more vulnerable to serious damage from high winds.
- ✓ If the siding or roofing on your building is attached with metal clips, make sure they are strong enough to resist the force of the wind without bending. If you can bend a clip with your hands, it is likely to fail when high-winds act on the siding or roofing.

- ✓ Windows and glass doors are usually more susceptible than walls and roofs to penetration by windborne debris. You should consider protecting windows and glass doors with permanent or temporary covers that can be closed or installed before a storm arrives. For more information, refer to the separate high wind protection fact sheet titled “Protect Windows and Doors with Covers.”
- ✓ You can also help protect your building against damage by windborne debris by removing or securely anchoring any loose objects on your property that could be picked up and moved by the wind. Trash, construction debris, warehouse pallets, and other loose materials should be removed or stored inside. Other objects, such as signs and trash cans, should be bolted down or held in place with chains or cables.

## **ESTIMATED COST**

A contractor will probably charge to inspect the exposed fasteners in a building with metal siding or a metal roof. If any modifications are necessary, the cost will depend on what must be done.

# Maintain EIFS Walls



# FEMA

## PROTECTING YOUR PROPERTY FROM HIGH WINDS

An Exterior Insulation Finishing System (EIFS) wall typically consists of several layers of materials sandwiched together into a single panel, which is then attached to a substrate mounted on the wall studs (see figure). The exterior of an EIFS wall is water resistant, but the wall can be weakened by moisture that becomes trapped behind the wall. The sources of this moisture are usually leaks around doors and windows and where the wall joins the roof. Once an EIFS wall has been weakened, it is more likely to be torn away or penetrated by high winds and windborne debris. If wind enters a building, the likelihood of severe structural damage increases, and the contents of the building will be exposed to the elements.

You should periodically inspect your EIFS walls, particularly the flashing where the walls meet the roof and all the seals around doors, windows, and any objects that pass through the wall, such as utility lines. Make sure that the flashing and seals have been properly installed and are not damaged.

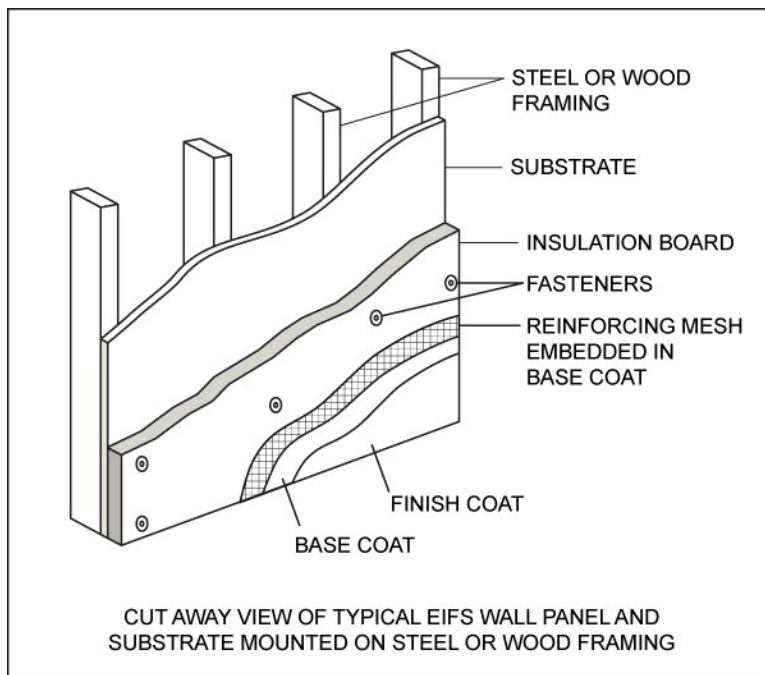

## BENEFITS OF UTILIZING THIS MITIGATION STRATEGY

- Helps to prevent damage to a structure and its contents
- Helps to prevent injuries to occupants

## TIPS

Keep these points in mind when maintaining your EIFS walls:

- ✓ A licensed contractor can test EIFS walls for moisture content and advise you on repairs.
- ✓ EIFS walls should be installed only by experienced contractors who have completed a manufacturer's training program. Contact the manufacturer or the EIFS Industry Members Association (EIMA) at 1-800-294-3462 or online at <http://www.eima.com> for more information.
- ✓ Most EIFS walls are susceptible to damage from windborne debris; however, impact-resistant walls have been developed by some EIFS manufacturers. Ask manufacturers whether their walls meet the wind load and impact standards established for your area. Your local building official can advise you about these standards.

- ✓ Ask your local building official about state and local code restrictions on the use of EIFS walls.
- ✓ EIFS walls have had mixed degrees of success in different parts of the country. Ask your local building official about the performance of EIFS walls in your area.
- ✓ EIFS manufacturers provide different types of fasteners and adhesives for buildings designed to withstand high wind loads. Ask the EIFS manufacturer and installer what the highest allowable wind speed is for your building and what can be done to help the walls withstand even higher wind speeds.

## **ESTIMATED COST**

EIFS wall costs vary; however, the cost of a typical EIFS wall is approximately \$4 to \$6 per square foot.



# Remove Trees and Potential Windborne Missiles



FEMA

## PROTECTING YOUR PROPERTY FROM HIGH WINDS

If the area immediately surrounding your home contains trees, outbuildings, trash cans, yard debris, or other materials that can be moved by the wind, your house will be more likely to be damaged during a hurricane or tornado. The wind can topple trees onto your house and can pick up smaller objects and drive them through windows and glass doors.

You should ensure that all trees on your property are far enough away to prevent them from damaging your home if they should fall. The distance between the structure and any nearby tree should always be greater than the height the tree will reach when it is fully grown. All storage sheds and other outbuildings should be securely anchored, either to a permanent foundation or with straps and ground anchors. Smaller objects, such as trash cans, barbecue grills, and outdoor furniture should also be anchored or, if you have adequate warning, moved indoors. You should also clear away any debris, such as fallen tree branches.

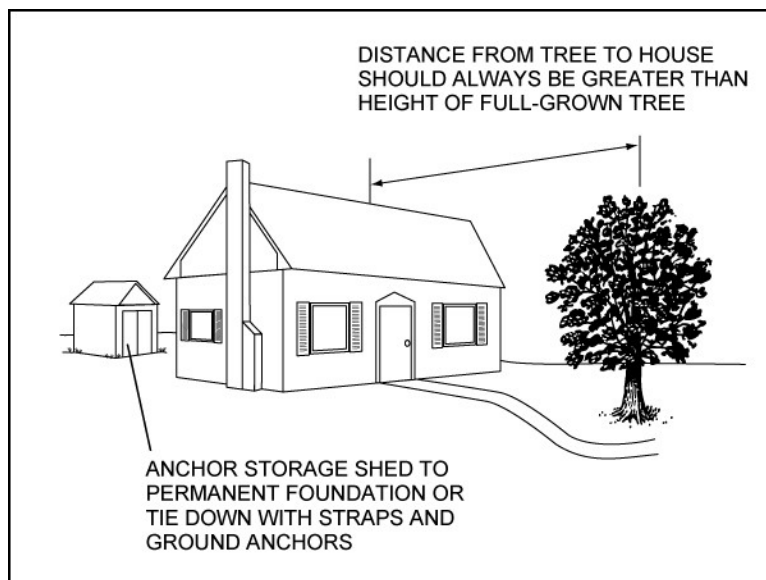

## BENEFITS OF UTILIZING THIS MITIGATION STRATEGY

- Helps to prevent damage to a structure and its contents
- Helps to prevent injuries to occupants

## TIPS

Keep these points in mind when you remove trees and potential windborne missiles:

- ✓ Remove large trees near your property. They can be extremely dangerous for both you and your home. Therefore, this is a job for a skilled contractor.
- ✓ Use the straps and ground anchors also used for manufactured homes to anchor outbuildings, especially small garden sheds that are usually not placed on a permanent foundation.
- ✓ Secure outdoor furniture and barbecue grills by bolting them to decks or patios or by attaching them to ground anchors with cables or chains.
- ✓ Secure trash cans with cables or chains attached to ground anchors or wood posts firmly embedded in the ground. Trash can lids should be attached to cans with cables or chains.
- ✓ Contact your local agricultural extension office to get suggestions on which varieties of trees will be less susceptible to storm damage.

- ✓ Contact an arborist for assistance with pruning existing trees properly. Improperly pruning trees or damaging root systems can make them more susceptible to storm damage.

## **ESTIMATED COST**

If you hire a contractor to remove a large tree, you can expect to pay about \$1,000 to \$1,500. Having a contractor anchor a storage shed with straps and ground anchors will cost about \$100 to \$200.